

AS2818, AS4118, AS5918 stepper motor with terminal box



Option



Connector configuration

M12 - 5-pin (MOTOR)		M12 - 8-pin (ENCODER)	
Pin	assignment	Pin	assignment
1	A\	1	A
2	A	2	A\
3	B	3	B
4	B\	4	B\
5	Housing	5	GND
		6	I
		7	I\
		8	Vcc
		Housing	GND/shielding

M12 connector

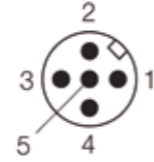

M12 connector

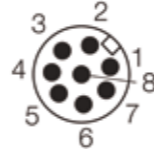

M8 - 3-pin (BRAKE)	
Pin	assignment
1	Brake
3	Brake/GND
4	NC



Order identifier

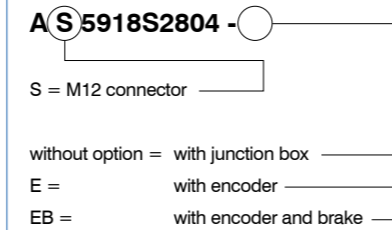

Connection cable:
Motor: ZK-M12-5-xx
Encoder: ZK-M12-8-xx
Brake: ZK-M8-3-xx
For further information, see section on "Cables"

The machine-compliant stepper motors up to a protection class of IP 65 (except for shaft output) offer a consistent drive concept. The matching flange dimensions mean that they are electrically and mechanically compatible with standard motors. The junction box on the rear panel makes the motors only slightly longer. Their main features include a large performance and application range as well as a high level of availability.

Encoders used:
3-channel with 500 pulses/revolution and line controller, 5 V TTL signal each (for 24V, please contact us!)

Available versions (others on request)

Type	Current A/phase	Holding torque Ncm	Resistance Ohm/phase	Inductance mH	Rotor inertia g cm ²	Weight kg	Length "A" mm	Encoder	Brake Nm
AS2818S0604	0.67	7.1	5.60	4.0	9	0.13	51.0		
AS2818L0604	0.67	12.7	9.20	5.6	18	0.22	70.3		
AS4118L1804	1.80	50	1.75	3.3	82	0.34	70.4		
AS4118L1804-E	1.80	50	1.75	3.3	82	0.34	70.4	X	
AS4118L1804-EB	1.80	50	1.75	3.3	82	0.34	106.4	X	0.4
AS5918S2804	2.83	85	0.75	2.6	230	0.80	73.0		
AS5918S2804-E	2.83	85	0.75	2.6	230	0.80	73.0	X	
AS5918M2804	2.82	105	0.85	3.6	300	0.85	77.0		
AS5918M2804-E	2.82	105	0.85	3.6	300	0.85	77.0	X	
AS5918L4204	4.20	198	0.50	1.9	480	1.14	98.0		
AS5918L4204-E	4.20	198	0.50	1.9	480	1.14	98.0	X	
AS5918L4204-EB	4.20	198	0.50	1.9	480	1.14	138.0	X	1

Outline drawing AS28, AS41, AS59 for flange size 28, 42 and 56

AS2818

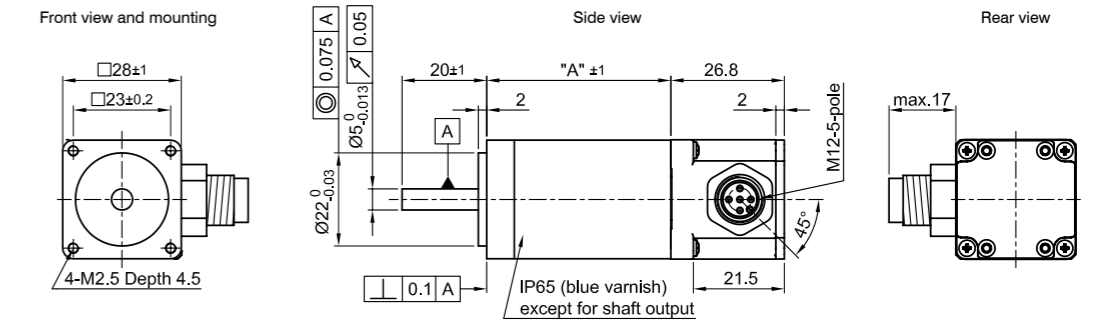

AS4118L1804 AS4118L1804-E

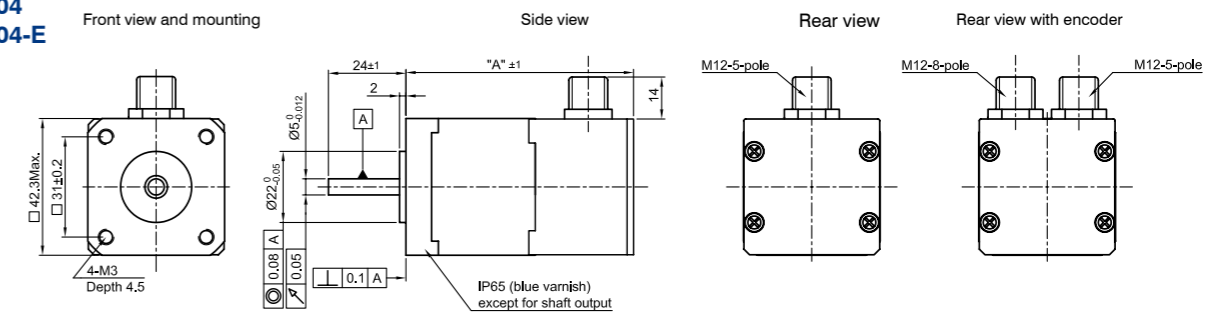

AS4118L1804-EB

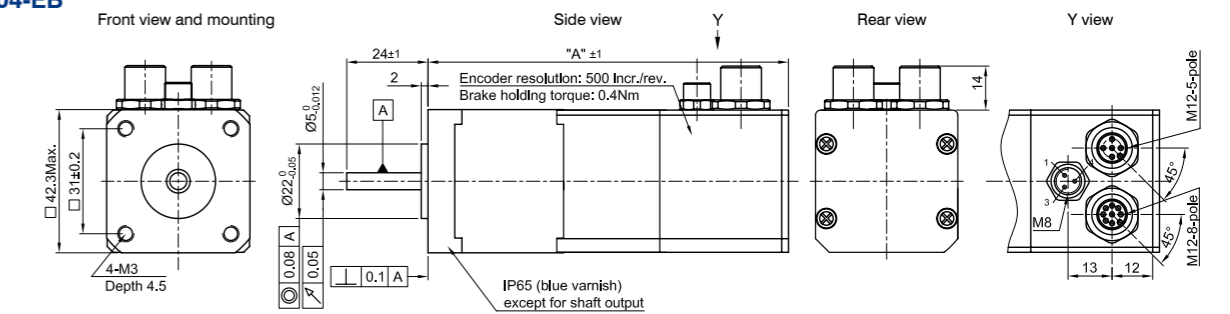

AS5918 AS5918...-E

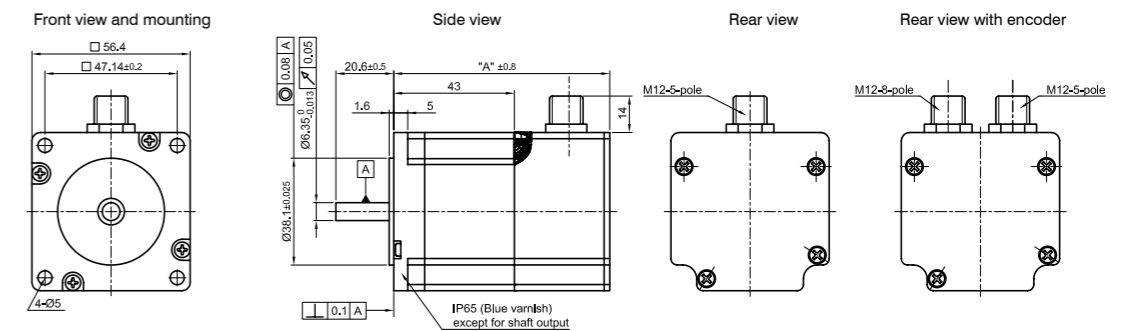

AS5918L4204-EB

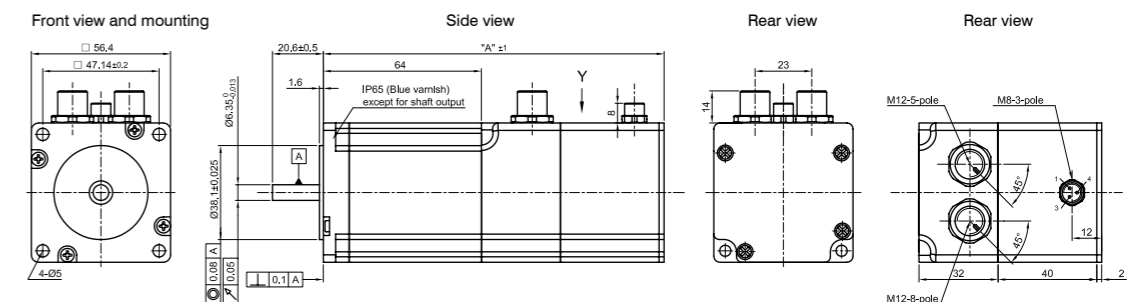

Speed/torque curves

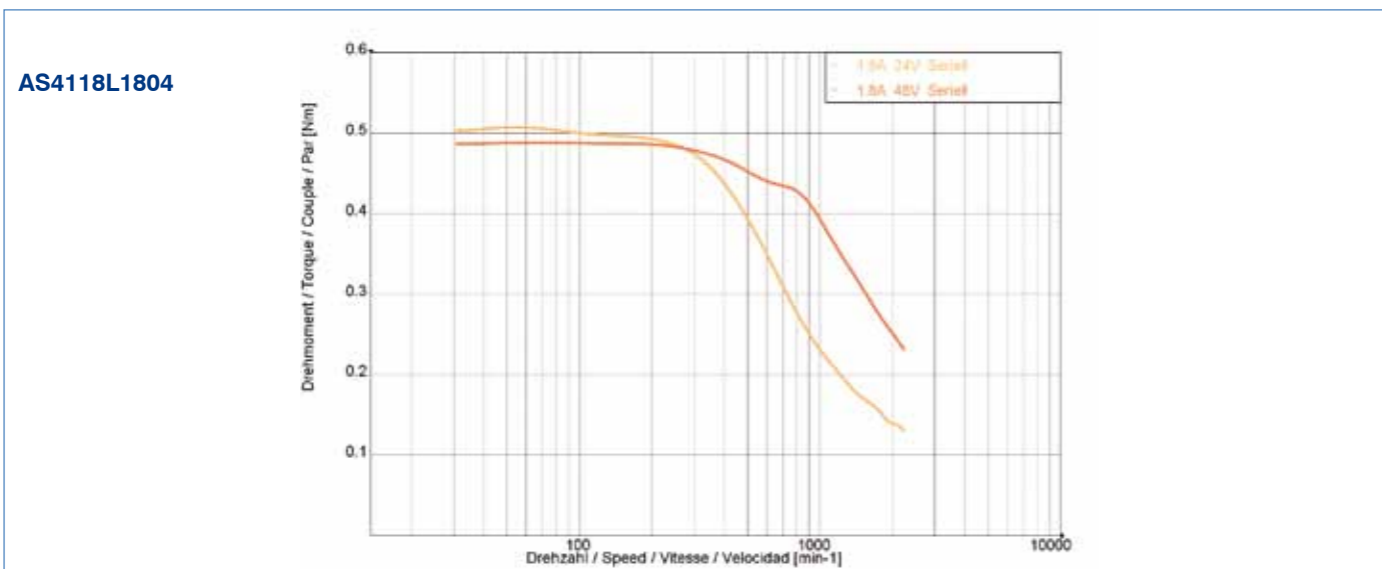
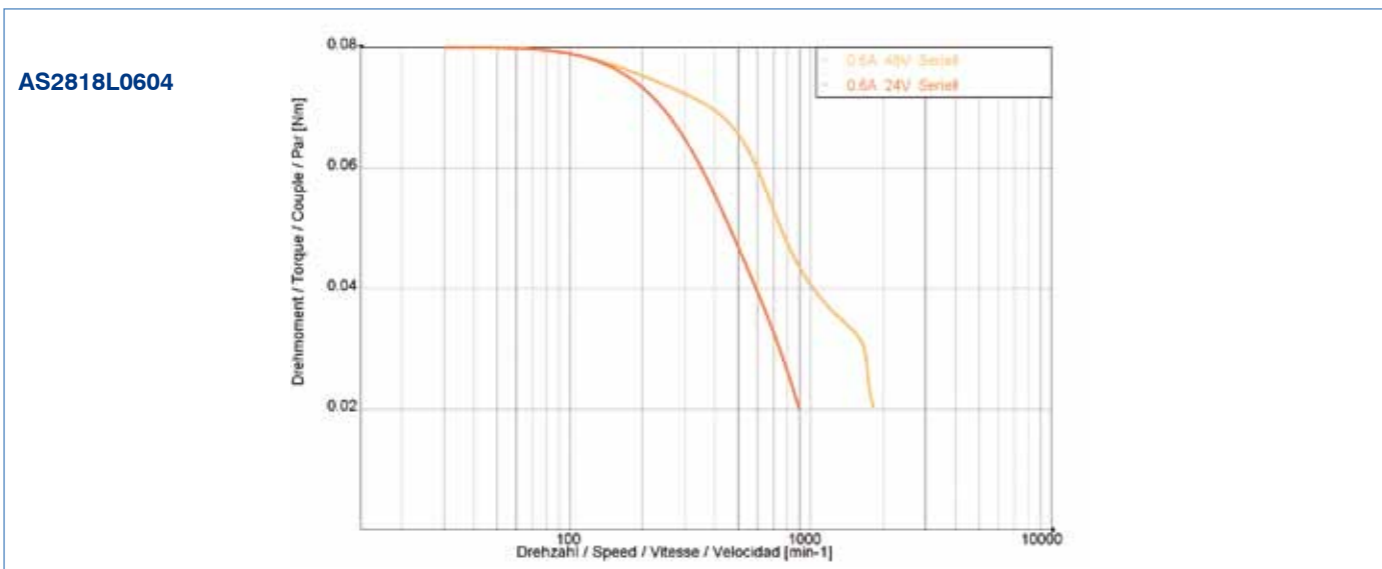
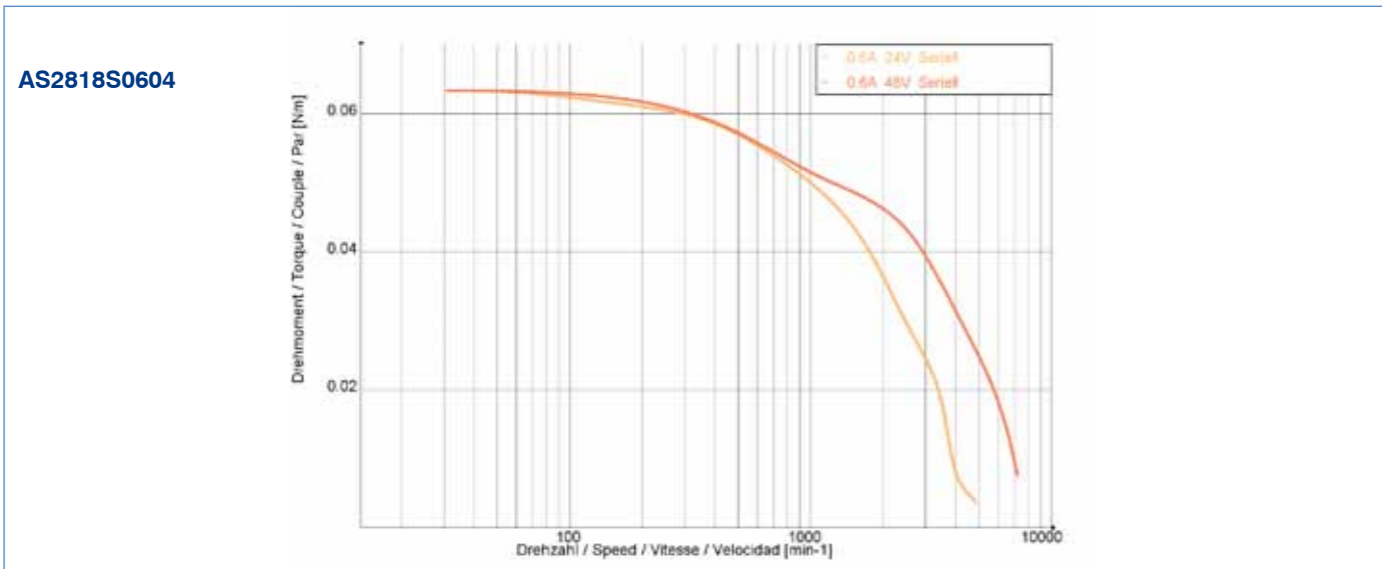

Speed/torque curves

