

Stepper motor drivers

Compact microstep driver, SMC11



Technical data

Operating voltage:	DC 12 V to 35 V
Max. phase current:	1.0 A/full step (1.25 A with cooling block) 1.4 A/microstep (1.8 A with cooling block) via potentiometer
Current setting:	Bipolar
Operating mode:	Full (1/1), half, quarter, eighth step (preset)
Protection function:	Overcurrent, overvoltage and overtemperature
Step frequency:	0 to 200 kHz
Current drop:	Switchable to 40%
Input signals:	0 V active (L < 0.8 V; 3.5 V < H < 6 V or open)
Temperature range:	0 to + 40°C
Connection type:	JST plug connector
Weight:	10 g
Mounting type:	2 boreholes on Ø 19.05 for M2.5 - mounted directly on stepper motor

I Note: A charging capacitor of at least 4,700 µF (Z-K4700/50) must be provided on the supply voltage so that the admissible voltage is not exceeded during the braking process. The connection to the motor must not be disconnected during operation! If the power supply or motor is not correctly connected, this can destroy the controller!

Outline drawing (mm)

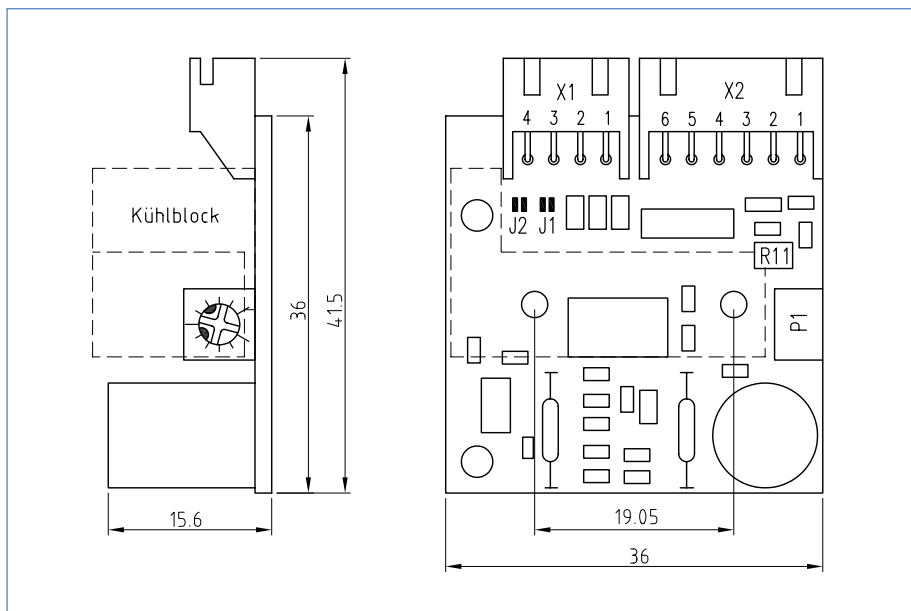

Input configuration, X1:

1=	Phase A
2=	Phase A\
3=	Phase B
4=	Phase B\

Input configuration, X2:

1=	Operating voltage, VSS
2=	Enable (L=active, H or open = disable)
3=	Direction
4=	Clock
5=	Operating voltage (0 V GND)
6=	Current drop

Input circuits

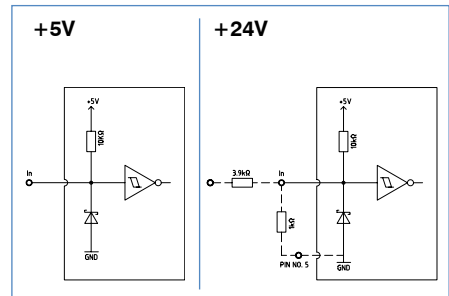

Order number

SMC 11 - 2
1/16 step automatic current reduction

Step switching

Configuration:
The module is configured to 1/8 step in the factory.

Step mode	J1	J2
1/1 step	X	X
1/2 step	X	
1/4 step		X
1/8 or 1/16 step		

Current setting

Max. phase current: (microstep)

P1

1.4 A (without cooling block)

P1

1.8 A (with cooling block only)